



Description

The DC Modular Remote Battery Switch (RBS) and Battery Protect Relay (TBP) are smart high current magnetic latching contactors, that can handle continuous DC currents of up to 500Amps. The contactors can easily be installed in an engine room or battery compartment, while being controlled from a more convenient location by a small panel mounted switch. The RBS / TBP can however also be controlled by a battery monitor or managed lithium battery.

Besides controlling the contactors remotely, buttons positioned at the top also provide a way to open or close the main contact locally, as required by Marine Standards. A 5 wire interface cable is used to control the contactors externally. For optimal flexibility, these can be configured to accept two wire or single wire open and close commands. A wire for providing a contact status feedback signal is also available.

Status LEDs on top clearly indicate whether the main contact is opened or closed. These indicators also provide additional visual feedback like operating- and error modes.

A specially developed internal solenoid guarantees a powerful contact drive, even when supplied by deeply discharged batteries.

Both the RBS and the TBP can be used to switch battery loads, through local and/or external control. The TBP however, has a number of additional features. The most important one being built-in battery protection.

The TBP will automatically open the main contact once the battery voltage has dropped below a programmable low voltage level. When subsequently the battery voltage has risen above the programmable reconnect voltage, the main contact is closed again.

Another handy TBP feature is the Override mode. In situations where the TBP has opened the main contact due to a battery undervoltage, long-pressing the close button (local or external) will close the main contact for 1 minute. This allows the user to jumpstart a low battery system. When after this minute the battery voltage remains too low, the contact will open up again. But it remains closed when during the override time, a charger has been connected causing the battery voltage to recover.

Being a member of the DC Modular product line up, the RBS and TBP can be perfectly integrated into very compact DC distribution systems.

Features

- Electronically controlled magnetic latching contactor
- Extremely low power consumption (< 100µA)
- 500Amp nominal current
- 60Vdc contact rating
- Local and external open / close control
- Visual status indicators

- Small footprint
- DC Modular grid compatible for compact and easy arrangements of multiple devices
- Selectable control modes
- Battery protection (TBP only)
- Override mode (TBP only)

Applications

- Battery management systems
- Marine applications
- Off grid solar power systems
- Battery load shedding applications
- Service vehicles
- Recreational vehicles
- Industrial systems

Technical specifications



| Parameter | DCM-RBS-12-500 art # 5074510 | DCM-RBS-24-500 art # 5074520 | DCM-TBP-12-500 art # 5074410 | DCM-TBP-24-500 art # 5074420 |
|--|---|---------------------------------|---|---------------------------------|
| Main contact circuit (electrical) | | | | |
| Rated voltage | | | 60Vdc | |
| Nominal current | | | 500A | |
| Cranking current (1 min.) | | | 1000A | |
| Nominal make / break current | | 500A (0 – 34Vdc) | 350A (35 – 60Vdc) | |
| Peak make / break current | | 1600A (0 – 34Vdc) | 1200A (35 – 60Vdc) | |
| Control circuit (electrical) | | | | |
| Coil / supply voltage (+Vdc) | 7 – 17Vdc | 14 – 34Vdc | 7 – 17Vdc | 14 – 34Vdc |
| Coil / supply current (idle state) ¹⁾ | | | < 100uA | |
| Coil / supply current (state change) ¹⁾ | < 4A | < 3A | < 4A | < 3A |
| Features | | | | |
| Remote battery switch function | • | • | • | • |
| Battery protect function | x | x | • | • |
| Local open / close controls | • | • | • | • |
| External open / close control wires | • | • | • | • |
| Contact status indicators | • | • | • | • |
| Contact status feedback wire | • | • | • | • |
| Override mode ²⁾ | x | x | • | • |
| Number of control modes | 5 | 5 | 7 | 7 |
| Programmable disconnect voltages | x | x | 9.0 – 12.2Vdc | 18.0 – 24.5Vdc |
| Programmable reconnect voltages | x | x | 10.5 – 13.8Vdc | 21.0 – 27.5Vdc |
| General | | | | |
| Remote control | By control wires | | | |
| Local control ³⁾ | Top side buttons (On/Standby, Close contact, Open contact) | | Top side buttons (On/Standby, Close contact, Open contact, Override mode) | |
| Indicators | Top side LEDs for Contact open, Contact closed, Error and Setup | | | |
| Mechanical / Electrical life | 100000 cycles / 10000 cycles | | | |
| Operating temperature range | -20..+60°C | | | |
| Connection stud size | M10 | | | |
| DC Modular grid size | 1 x 3 | | | |
| Protection class | IP65 | | | |
| Dimensions | 150.0 x 50.0 x 94.0 mm | | | |
| Weight | 800gr | | | |
| Standards | CE certified (EMC Directives UNECE Regulation 10 and 2014/30/EU, Low voltage Directive 2014/35/EU, RoHS Directive 2011/65/EU and Ignition protection standard ISO 8846) | | | |

Note: the given specifications are subject to change without notice.

¹⁾ Due to the magnetic latch construction, the DCM RBS and TBP draw virtually no current in the ON or OFF state. A current draw only exists shortly (500ms max) when changing the state of the contact.

²⁾ Override mode allows the contact to be temporarily closed, despite being automatically opened earlier due to a battery under voltage. This is intended for jumpstarting a low battery system.

³⁾ Using the top side buttons, one can manually override the switch state as commanded through the control wires. A dedicated 'On/Standby' button also allows the user to put the DCM RBS or TBP in a standby mode with open contact. In this mode any commands from the control wires and/or manual override buttons are ignored.

Accessories

Panel Switch Momentary SPDT + LED art# 5095000-1

With this optional panel switch you can send open and close commands to the RBS and TBP contactors from a convenient location. The integrated LED indicates when the contact is closed or when the contactor is running in a certain mode.



Dimensions (Contactors)

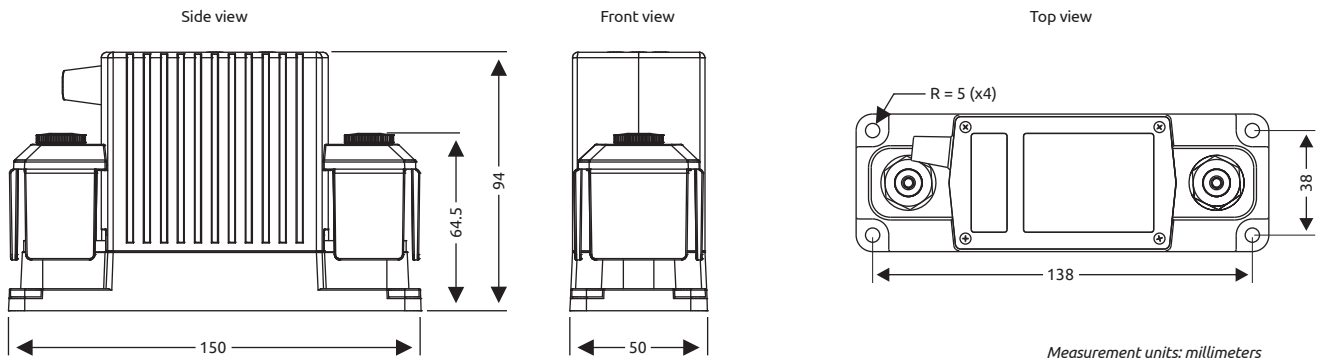

Dimensions (Panel switch)

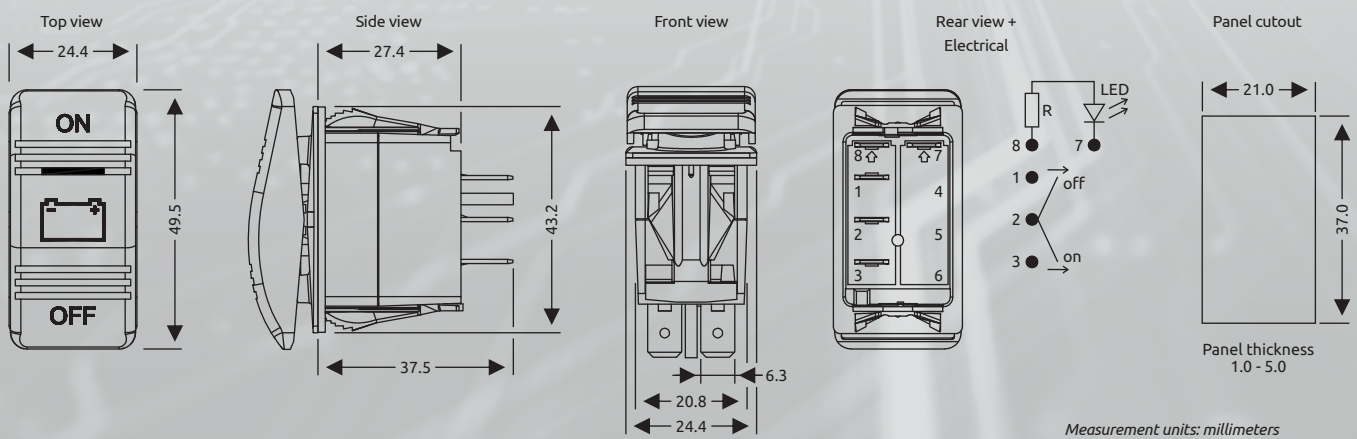

Basic application diagram

